



INSTALLATION MANUAL

MB4K ONBOARD BASS PREAMP WITH MID BOOST (4-KNOB SYSTEM), INCLUDING CONTROL PLATE

Master Volume / Balance / Vintage Tone Control (P/P) / Treble and Bass (stacked) / Mid Boost Toggle Switch

Thank you for purchasing your Sadowsky® Onboard Bass Preamp 4-Knob system with mid boost! The set includes the famous Sadowsky preamp with volume and balance controls, controls for the passive Vintage Tone Control (VTC) and a tandem potentiometer for active EQ control with bass and treble boost. The push/pull function of the VTC pot allows the bass to be switched between active and passive mode. VTC works in both modes. It also features a 500 Hz mid boost that can be switched on/off with a toggle switch.

The system is pre-wired with the components pre-mounted on a control plate and it includes the output jack and the battery clip. It is designed for installation on most J-style basses with a 4-hole metal control plate. On newer active J-style basses with a side jack and a battery compartment, usually no modification is required. In most cases, no soldering is required for the installation. Pickup wires and bridge ground can be connected to screw-terminals on the balance pot.

Control functions

- **Volume control:** fully right = max. volume
 - **Balance control:** switches between the two pickups (end positions) or mixes the signal from both pickups (intermediate positions), middle position = 50/50 mix
 - **Bass / Treble:** only boost available, fully left = neutral position (no boost), fully right = 18 dB boost at 40 Hz / 4 kHz
 - **Vintage Tone Control (VTC):** passive treble cut (works in passive and active mode), fully right = no treble cut
 - **Push/Pull switch on VTC control:** switches between passive mode (preamp in bypass) and active mode
- Note:** Switching to passive does not turn off the battery. The battery is activated any time a cable is plugged into the output jack. Remove the cable during long breaks and when not using the bass.
- **Toggle switch:** switches 500 Hz mid boost on/off.

Instrument requirements

- The preamp is designed for two **passive pickups** and is not compatible with active pickups that require anything other than a 250K or 500K volume or balance pot.
- The instrument must have routings for the installation of a J-style control plate and a side-mounted jack.
- Some passive vintage J-style basses with control plates may require moving the jack to the side of the bass, and routing a cavity large enough to contain the battery and the circuit board.
- If you do not have experience with routing or drilling or if you are unsure how to proceed with the installation, we strongly recommend that you have the installation performed by a guitar technician.

The kit includes

- Pre-wired preamplifier circuit with PCB, potentiometers, toggle switch (already mounted on a J-style control plate), battery clip and output jack
- Note:** The included jack has METRIC threads and will not work with Imperial threaded jack plates.
- Instructions/circuit diagram
- Allen wrench for attaching the knobs
- Wood screws for attaching the control plate

Tools required

- Screwdriver to remove the old control panel
- Small screwdriver for the terminal screws on the balance pot
- Possibly a soldering iron for unsoldering pickups and bridge ground from old components

Specifications

- Frequency response 5 Hz - 50 kHz
- Gain (in active mode) +1.5 dB Boost
- Bass control + 18 dB Boost at 40 Hz
- Mid boost switch +10.6 dB Boost at 500 Hz
- Treble control + 18 dB Boost at 4 kHz
- Total Harmonic Distortion (THD) 0,18% at 1 kHz
- Power source one 9 V battery
- Current draw 9 mA
- Battery life up to 870 hours*
- Input impedance 1 MOhm
- Output impedance 1 KOhm

* **Note:** The battery drains as soon as a cable is plugged into the output jack. Switching to bypass does not extend battery life. With normal use, you can expect a battery life of around six months.

Installation

No soldering is required to install the preamplifier kit. However, soldering may be required to remove the old electronics. All connectors are keyed to prevent incorrect connection. You can verify that the connections are correct by comparing the wire colors to the color code in the schematic below.

- Remove the old control plate and output jack from your instrument. If you need to keep the original output jack, it must be a stereo jack with three contacts (TRS), because the ring contact is used to close the circuit for the battery.
- Identify and mark the „hot“ and ground wires from the pickups and the bridge ground wire. When unsoldering the wires from the old components, make sure to leave a stripped and tinned piece of bare wire at the end that can be inserted into the screw terminals on the balance pot.
- Check that there is sufficient space in the electronics compartment for the new preamplifier electronics and a 9 V block battery. If there is no room for the battery, you will need a technician to install a separate battery compartment.
- If the compartment is not already shielded, we recommend shielding it now (shielding paint or copper foil).
- Find a suitable position for the circuit board in the electronics compartment. The PCB has double-sided tape attached to its back. Plug in the connectors and secure the PCB in the electronics compartment with the double-sided tape.
- Install the pre-wired output jack from the kit in the position of the old jack.
- The **pickup cables** are connected to the balance control with screw terminals. Connect the ground wires to the **black terminals** and the hot wires to the **green terminals**.

Note: The wires in the green terminals can be swapped to change the working direction of the balance control.

- The **bridge ground cable** can also be connected to one of the screw terminals for the ground contacts (black terminals), as these are large enough to accommodate two wires.
- Connect a **9 V battery** to the battery clip and insert the battery into the battery compartment.
- Attach the new control plate to your bass using the included screws.
- Plug an instrument cable into the output jack, connect an amplifier and test the function of the new electronics.

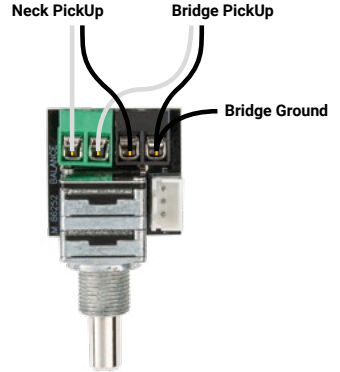

- 5 -

- 6 -

Schematic diagram

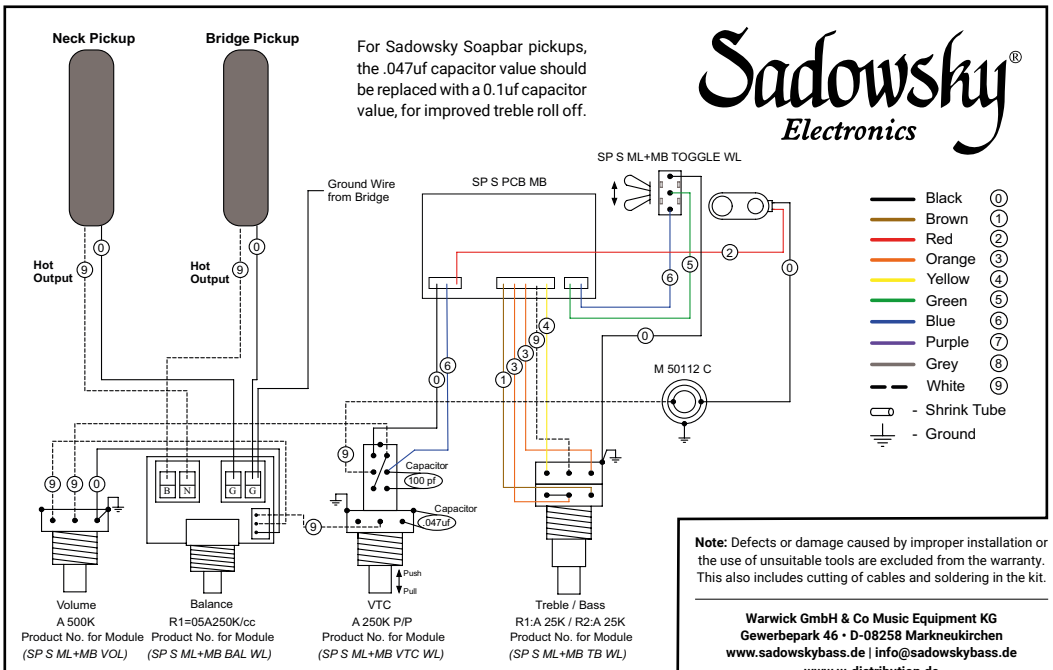

- 7 -

- 8 -